

SPECIFICATIONS

MCU223-UDD

520 Series 2-Door Integral Counter Chiller

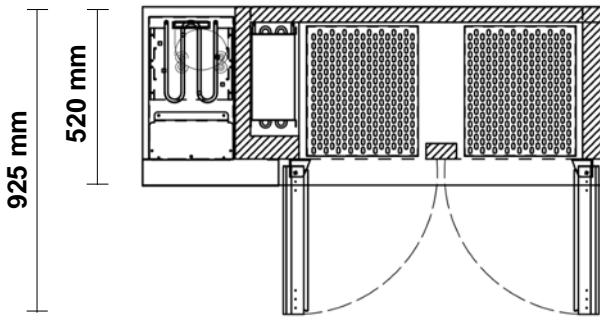
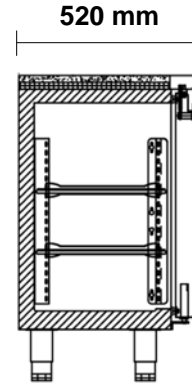
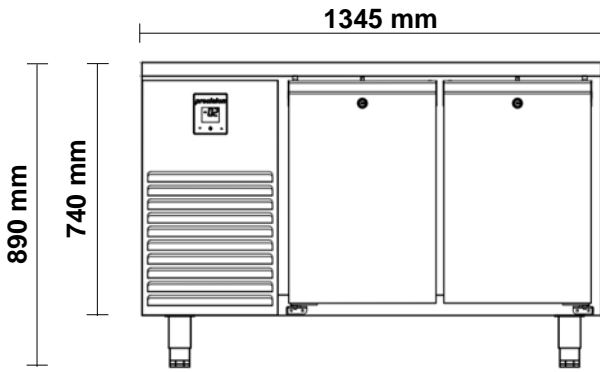

SPECIFICATIONS

Refrigeration system	Electronic controlled, self-contained, side mounted, refrigeration unit	
Refrigerant	R134a / 160g	
Nominal capacity	412 Watts @ -10°C SST	
Cabinet internal volume	120 litres	
Insulation	60mm thick, high density Zero ODP injected polyurethane insulation	
Cabinet temperature range	-2°C to +4°C up to 43°C ambient	
Drainage	Waste heat vaporiser located in service compartment (no plumbing required)	
Electrical	220-240 Volts a.c. 50 Hz, 1.6 Amps	
kWh/24hr	1.73	
Internal door opening size	2 door opening, accepts full 2/3 or 2 x 1/3 GN pans	
Doors	Stainless steel, self-closing, lockable solid door	
Worktop	Removable stainless steel worktop	
Shelves	2 shelves & adjustable tray slides per door (Total 4)	
Weight	110kg	
Cabinet dimensions	External	Internal
Width	1345mm	825mm
Depth	520mm	400mm
Height	700mm*	600mm

OPTIONS

- Glass Doors
- Bank of 2 Drawers
- Bank of 3 Drawers
- Remote Units
- Castors (standard on 150mm legs)
- Splashbacks
- Extended Worktops
- No Worktop
- Different Heights
- Raised Pan Grid
- Countertop Well
- Over-shelf / Gantry
- Water-cooled
- Extra Shelves
- Extra Slides
- ST/ST Back
- Heli-coil Cable
- Hydrocarbon Refrigerant
- HFO Refrigerant

* Height excludes castors, legs or SS worktop