

# H02UFB

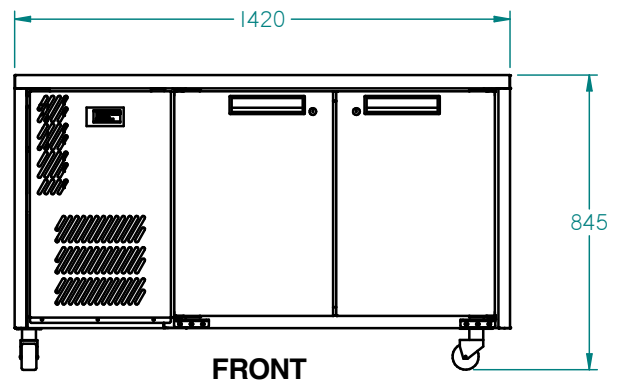

CATEGORY	FOODSERVICE COUNTERS
RANGE	<b>Opal</b>
UNIT	REFRIGERATOR
TYPE	SELF CONTAINED
DOORS	2

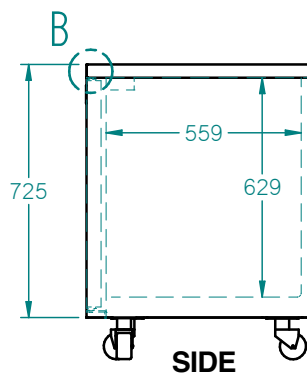
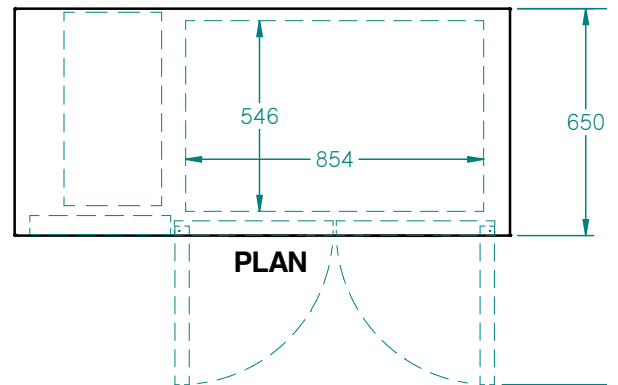

## SPECIFICATIONS

CAPACITY LITRES	350
TEMPERATURE	1°C / 4°C
FRONT BREATHING	YES
DIMENSIONS - W X D X H (ON CASTORS) MM	1420 W x 650 D x 845 H
WEIGHT UNPACKED (KG)	130

## STANDARD INCLUSIONS \*\*\*

DOOR TYPE	Standard: <b>SD</b> (Solid Door)    Optional: <b>DR</b> (Drawer), <b>GD</b> (Glass Door), <b>PT</b> (Pass Thru)
FINISH (INTERIOR AND EXTERIOR EXCLUDING REAR AND UNDER)	<b>SS</b> (Stainless Steel)
SHELVES/DOOR	2

## ELECTRICAL

POWER SUPPLY	10 amp
FRIDGE MODELS	<b>RUNNING AMPS</b> 2.8

## GAS TYPE

REFRIGERANT	FRIDGE MODELS	R134a
-------------	---------------	-------

\*\*\* For **OPTIONS** refer to the current Williams Price Guide