

HO1UFB

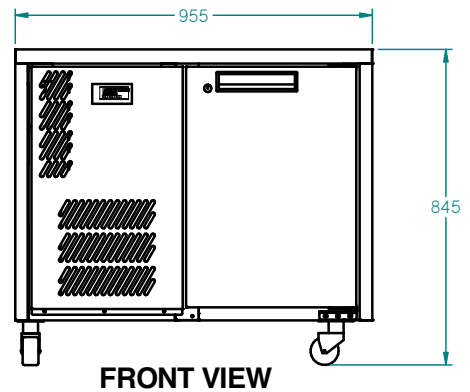

CATEGORY	FOODSERVICE COUNTERS
RANGE	Opal
UNIT	REFRIGERATOR
TYPE	SELF CONTAINED
DOORS	1

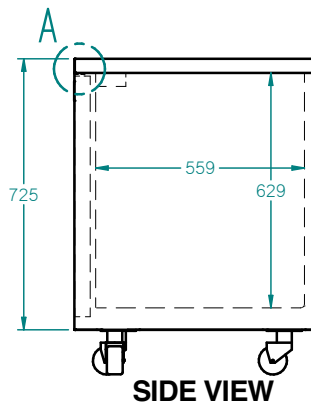
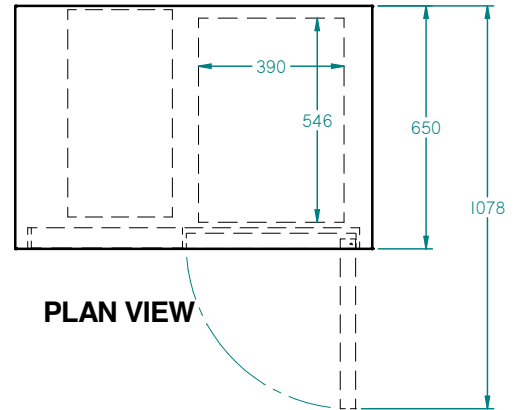

SPECIFICATIONS

CAPACITY LITRES	190
TEMPERATURE	1°C / 4°C
FRONT BREATHING	YES
DIMENSIONS - W X D X H (ON CASTORS) MM	955 W x 650 D x 845 H
WEIGHT UNPACKED (KG)	100

STANDARD INCLUSIONS ***

DOOR TYPE	Standard: SD (Solid Door) Optional: DR (Drawer), GD (Glass Door), PT (Pass Thru)
FINISH (INTERIOR AND EXTERIOR EXCLUDING REAR AND UNDER)	SS (Stainless Steel)
SHELVES/DOOR	2

ELECTRICAL

POWER SUPPLY	10 amp	
FRIDGE MODELS	RUNNING AMPS	2.0

GAS TYPE

REFRIGERANT	FRIDGE MODELS	R134a
-------------	---------------	-------

*** For **OPTIONS** refer to the current Williams Price Guide