

HG2SD

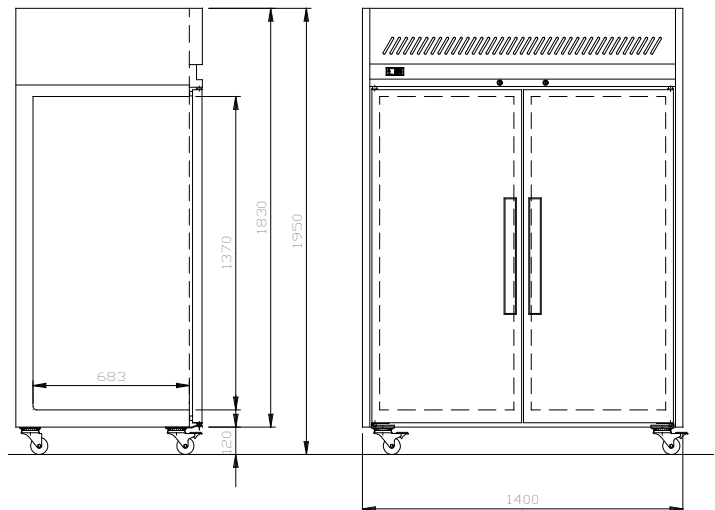

CATEGORY	GENERAL UPRIGHTS
RANGE	Garnet
UNIT	REFRIGERATOR
TYPE	SELF CONTAINED
DOORS	2

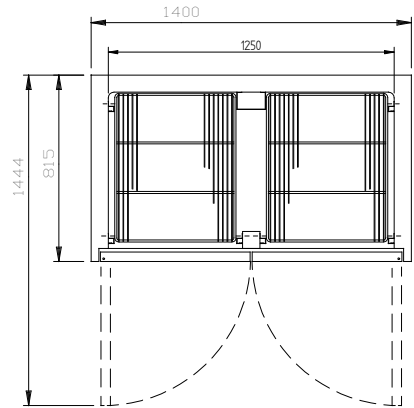

SPECIFICATIONS

CAPACITY LITRES	1270
TEMPERATURE	1°C / 4°C
DIMENSIONS - W X D X H (ON CASTORS) MM	1400 W x 815 D x 1950 H
WEIGHT UNPACKED (KG)	220

STANDARD INCLUSIONS ***

DOOR TYPE	Standard: SD (Solid Door) Optional: GD (Glass Door), PT (Pass Thru), HD (Half Door)
FINISH (INTERIOR AND EXTERIOR EXCLUDING REAR AND UNDER)	SS (Stainless Steel)
SHELVES/DOOR	4

ELECTRICAL

POWER SUPPLY (DUAL TEMP MODEL REQUIRES 2)	10 amp
FRIDGE MODELS RUNNING AMPS	5.3

GAS TYPE

REFRIGERANT FRIDGE MODELS	R134a
--------------------------------	-------

REFRIGERATION WATTAGES FOR OPTIONAL REMOTE UNITS

FRIDGE MODELS - SOLID DOORS	670 @ -5°C SST
-----------------------------	----------------

*** For **OPTIONS** refer to the current Williams Price Guide