

FD0900 | Food Display 900mm

Food Displays

FD0900

**FOOD DISPLAY
900MM**



FD0900 | Food Display 900mm

Food Displays

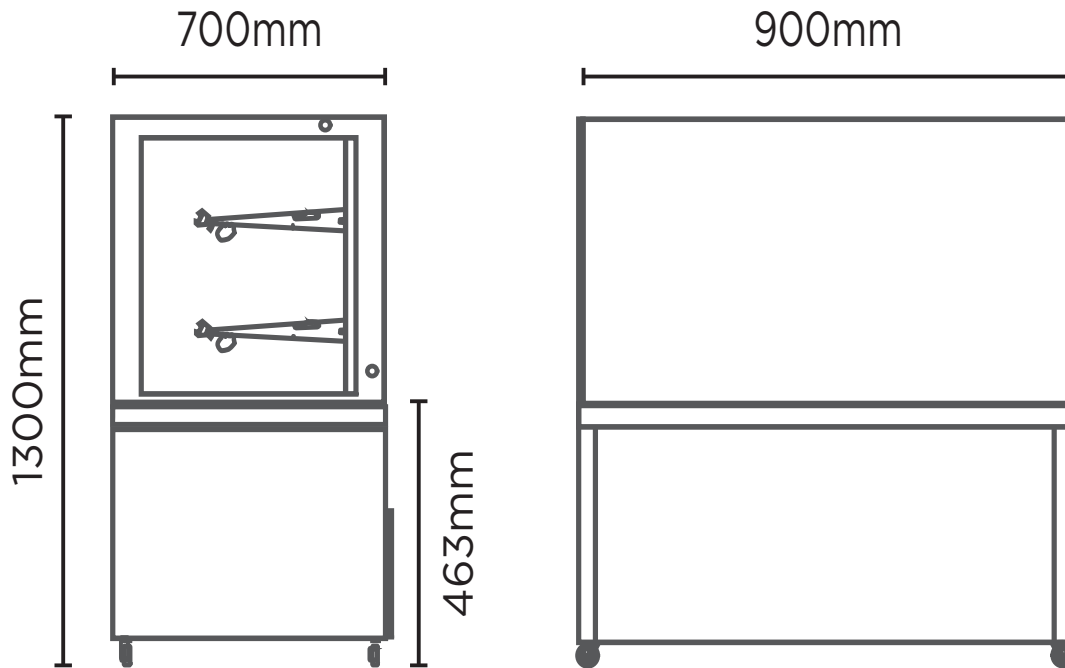

| | | |
|-------------------------|---------------------------------|--|
| SPECIFICATIONS | Part Number | 3335370 |
| | Capacity | 328L |
| | Temp. Range | +1 to +10°C |
| | Max. Ambient Temp. | 30°C |
| | Refrigeration Power | 659W |
| | Energy Consumption | 15.02kW/24h |
| | Gross Weight | 232kg |
| | Packaged Dimensions | 910 x 750 x 1350 mm |
| | Refrigerant | R134a |
| | Plug Supplied | Yes, 1 x 10A |
| | Plug Location | Rear, left hand side |
| | Main Light | LED |
| | Number of Doors | 2 |
| | Door Type | Slide |
| | Temp. Controller | Digital |
| | Castors | Yes |
| | No. of Shelves inc. Base | 3 |
| | Shelves Dimensions | 386(w) x 280(d), 386(w) x 333(d), 364(w) x 382(d) mm |
| Colour | Stainless Steel | |
| Warranty | 1 Year Parts & Labour | |
| Warranty Service | Bromic Extra Care | |

| | | |
|-------------------|----------------------|------|
| DIMENSIONS | External (mm) | |
| | Width | 900 |
| | Depth | 700 |
| | Height | 1300 |
| | Internal (mm) | |
| | Width | 760 |
| Depth | 580 | |
| Height | 700 | |

BROMIC PTY Ltd reserve the right to alter specifications without notice.