

SPRING

SERVE-OVER DELI COUNTER



FEATURES INCLUDE:

Curved lift up glass
Front glass demister
Canopy lighting incl. switch
Refrigerated storage under
Rear perspex slides

Electronic temperature control
Condensation removal via hot gas discharge
Castor wheels (optional)
Non-refrigerated internal shelf (optional)

SPRING

SERVE-OVER DELI COUNTER

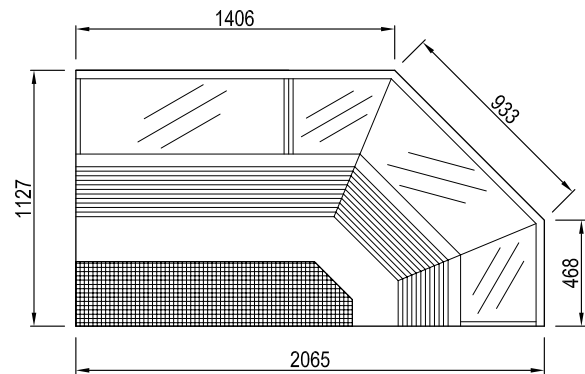
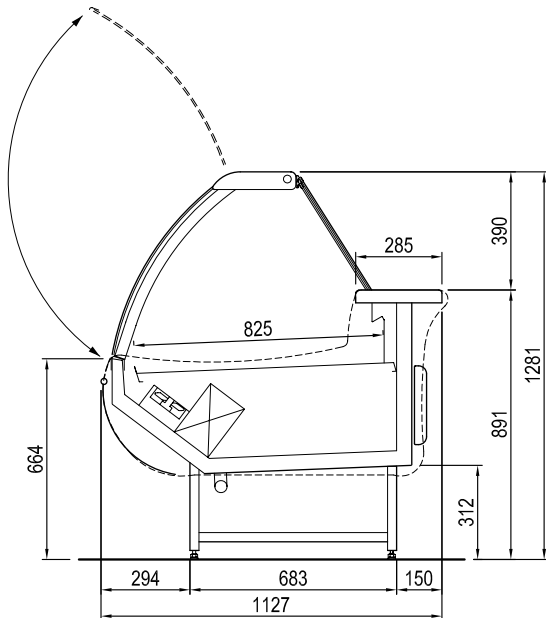

SPRING R/H CNR

| SPRING | 1250 | 1563 | 1875 | 2500 | 3125 | 3750 | 90° R/H CNR |
|-----------------------------------|----------------------|--------|-------|-------|-------|-------|-----------------|
| * Operating Temp (°C) | 0/+2 | 0/+2 | 0/+2 | 0/+2 | 0/+2 | 0/+2 | 0/+2 |
| Refrigeration | Ventilated/R404a | | | | | | |
| Defrost | Automatic | | | | | | |
| Power Supply | 230V/1Ph/10 Amp plug | | | | | | |
| Operating Current (Amp) | 1.5 | 1.8 | 2.7 | 2.8 | 4.0 | 4.3 | 2.7 |
| Nominal Power (W) | 335 | 405 | 605 | 640 | 910 | 980 | 620 |
| Energy Consumption (kWh/24h) | 6.75 | 7.26 | 10.88 | 12.73 | 17.56 | 18.42 | - |
| Display Surface (m ²) | 1.03 | 1.29 | 1.54 | 2.06 | 2.57 | 3.09 | 1.65 |
| Length w/o endwalls (mm) | 1250 | 1562.5 | 1875 | 2500 | 3125 | 3750 | Refer to layout |
| Endwall thickness (mm) | 50 | 50 | 50 | 50 | 50 | 50 | 50 |
| Height w/o castors (mm) | 1281 | 1281 | 1281 | 1281 | 1281 | 1281 | 1281 |
| Height incl. castors (mm) | 1361 | 1361 | 1361 | 1361 | 1361 | 1361 | 1361 |
| Depth incl. bumper (mm) | 1127 | 1127 | 1127 | 1127 | 1127 | 1127 | 1127 |
| Weight w/o packaging (kg) | 150 | 180 | 210 | 270 | 340 | 400 | 220 |

* Climate class 3 (25°C, 60%R/H)