

# ESPRIT 200

SERVE-OVER PATISSERIE COUNTER



## FEATURES INCLUDE:

Flat bottom hinged glass (15° opening)  
Internal and external stainless steel AISI 304  
LED canopy lighting incl. switch  
Rear plexiglass doors  
Evaporator with anti corrosion treatment

Internal air flow controller (fan speed regulator)  
1 glass shelf without lighting  
Castor wheels (optional)

# ESPRIT 200

SERVE-OVER PATISSERIE COUNTER

**CRIO CABIN**  
TASTE PRESENTATION

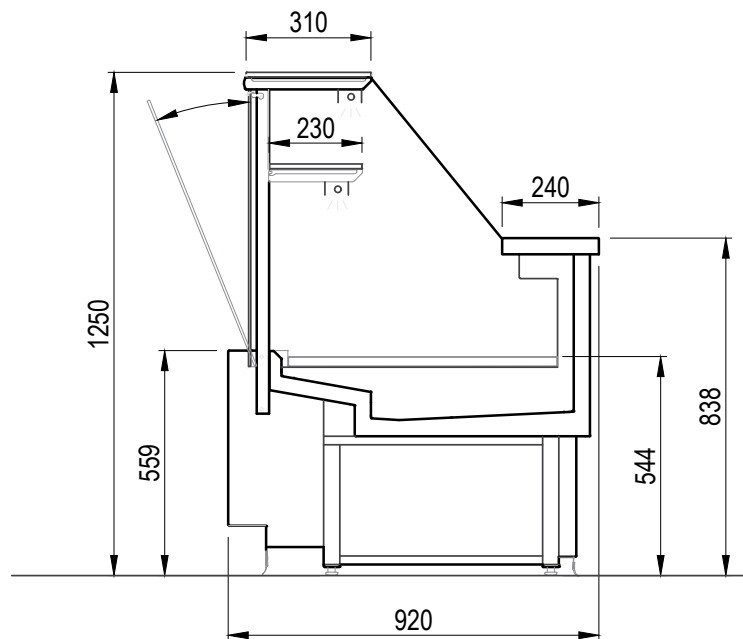

\*Lower lamp optional.

ESPRIT 200	**937	**1250	**1875	**2188	**2812
* Operating Temp (°C)	+2/+4	+2/+4	+2/+4	+2/+4	+2/+4
Refrigeration	Ventilated/R404a				
Defrost	Automatic				
Power Supply	230V/1Ph/10 Amp plug				
Operating Current (Amp)	2.3	2.4	5.2	5.3	6.7
Nominal Power (W)	400	410	890	920	1150
Energy Consumption (kWh/24h)	7.2	7.4	16	16.6	20.7
Power Requirements	2.3	2.4	5.2	5.3	6.7
Display Surface (m <sup>2</sup> )	0.63	0.84	1.26	1.47	1.88
Length (mm) with endwall	1017	1330	1955	2268	2892
Endwall thickness (mm)	40	40	40	40	40
Height w/o castors (mm)	1250	1250	1250	1250	1250
Height incl. castors (mm)	1336	1336	1336	1336	1336
Depth w/o bumpers (mm)	920	920	920	920	920
Depth w bumpers (mm)	982	982	982	982	982
Weight w/o packaging (kg)	145	160	185	200	230

\* Climate class 3 (25°C, 60%R/H)

\*\* Ex factory item