

ENIXE 100 SELF SERVE

SELF SERVE DELI COUNTER



FEATURES INCLUDE:

E1100 self serve deli counter
Perspex front riser
Front glass demister
LED canopy lighting
Rear perspex slides
Castor wheels (optional)

Rear refrigerated storage compartment
Evaporator with anti corrosion treatment
Internal air flow controller (fan speed regulator)
Internal in stainless steel AISI 304

ENIXE 100 SELF SERVE

SELF SERVE DELI COUNTER

CRIOCABIN
TASTE PRESENTATION

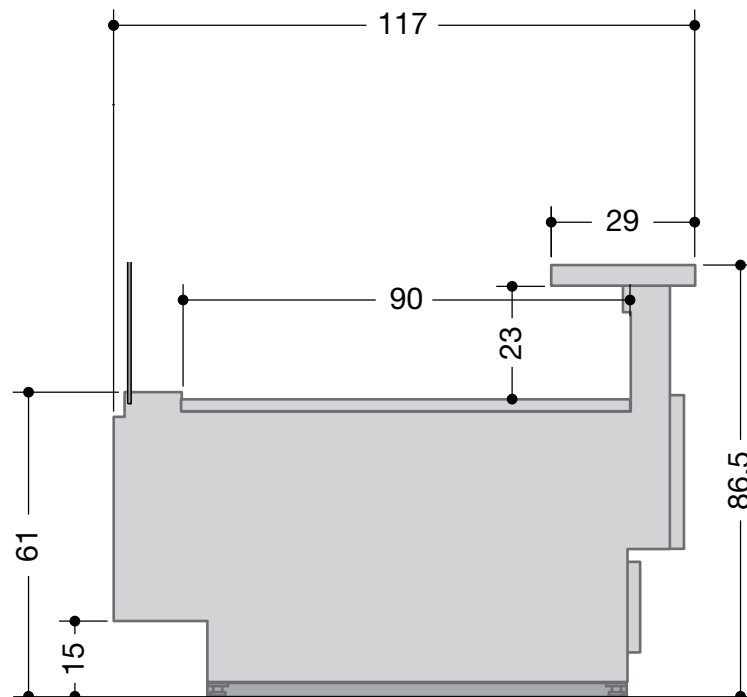

ENIXE 100	937**	1250**	1875	2500	3125	3750
* Operating Temp (°C)	+2/+4	+2/+4	+2/+4	+2/+4	+2/+4	+2/+4
Operating Current (Amp)	1.9	2.0	3.0	3.4	5.3	5.4
Refrigeration	Ventilated/R404a					
Defrost	Automatic					
Power Supply	230V/1Ph/10 Amp plug					
Nominal Power (W)	435	445	678	776	1210	1230
Energy Consumption (kWh/24h)	7.8	8	12.2	14	21.7	22.1
Display Surface (m ²)	0.84	1.13	1.69	2.25	2.81	3.38
Length (mm) with endwall	1017	1330	1955	2580	3205	3830
Endwall thickness (mm) endwall	40	40	40	40	40	40
Height w/o castors (mm)	1200	1200	1200	1200	1200	1200
Height incl. castors (mm)	1260	1260	1260	1260	1260	1260
Depth w/o bumpers (mm)	1160	1160	1160	1160	1160	1160
Depth w bumpers (mm)	1222	1222	1222	1222	1222	1222
Weight w/o packaging (kg)	150	175	220	260	340	410

* Climate class 3 (25°C, 60%R/H)

** Ex factory item