

ACBL15

STANDARD FEATURES

- › **Frameless** single-glazed glass canopy with UV bonded seams
- › Fan assisted cold air blanket across floor of cabinet
- › Single level display
- › **DuraCoat** system providing a protective coating over the refrigeration coil to prevent food acid corrosion
- › Refrigeration unit provided as Integral (condenser in cradle)
- › **SlimLED** lighting system with 12V safety off top rear rail
- › **SureVap** self-evaporating system for condensate - no drain required
- › High quality European refrigeration components
- › Rear sliding doors on friction-free, low wear tracks (doors removable for cleaning)

For Factory Options refer to page 60

For Cabinet Accessories refer to page 72

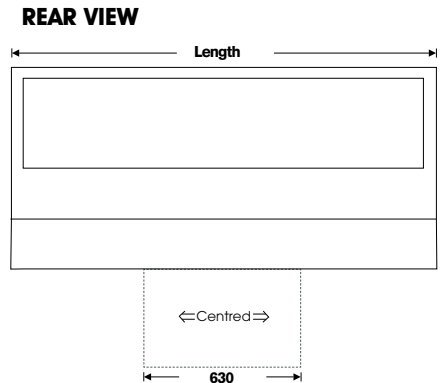
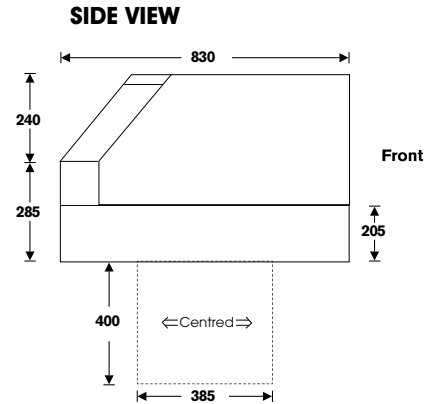

AVON LO: CHILLED BENCHTOP

This architecturally designed frameless cabinet is ideal for high-end patisserie or delicatessen style displays

4°C operating temperature

Model	ACBL9	ACBL12	ACBL15	ACBL18	ACBL24
Length	900mm	1200mm	1530mm	1770mm	2370mm
Depth*	830mm	830mm	830mm	830mm	830mm
Height	525mm	525mm	525mm	525mm	525mm
Available Display Area	0.54m ²	0.72m ²	0.92m ²	1.1m ²	1.44m ²
Power Connection	10A Plug	10A Plug	10A Plug	10A Plug	10A Plug

*Add extra 30mm for protruding control panel, switches and cable exit