

The Lincoln 2500 series Digital Countertop Impinger (CTI), is a self-contained conveyerised electric Impinger oven that is stackable up to two high and designed for countertop use.

The digital oven controls are located on the front of the oven and include a power on/off switch, temperature control and conveyor speed control.

The push button control panel with a digital temperature display and 4 preset menu options provides a 'simple-to-operate' end-user experience with consistent throughput.

The conveyor is reversible (right to left / left to right) from the control panel allows easy placement within different kitchen environments. Menu flexibility is enhanced due to an improvement of the adjustable conveyor speed so that it now ranges from 30 seconds to 15 minutes.

Features a robust 'stepper' motor and a wide temperature range of 32°C to 315°C. Conveyor and air distribution fingers are removable through the side panels for cleaning.

Must be used with included 100mm legs for proper cooling.

Includes 1270mm conveyor with end stop and crumb trays below the belt outside the baking chamber.

STANDARD FEATURES

- Air Impingement
- Uniform heating/cooking of food
- Oven has one self-contained heating system
- Reversible conveyor direction switch on front control panel
- Push button controls assure consistency and are easy for operators to program and adjust
- 4 Programmable set-menu controls
- Ventless operation for single deck. Local codes apply.

DIMENSIONS		
1270W x 797D x 457H mm (single deck)		
1270W x 797D x 813H mm (double deck)		
Clearance: Rear:152mm		Right side:610mm
PRODUCTION EXAMPLE PER DECK		
Single deck: 48 x 8" pizzas/hour at 6:30 mins		
TECHNICAL DATA		
Model	Power Supply	Output
2504-1	1NAC 240V 1 Phase 50Hz 25amp Lead and Plug Not Included	6kW
SHIPPING DATA		
Shipping dimensions: 1500W x 1100D x 600H mm		
Shipping weight: 93kg		

SPECIFICATIONS ARE SUBJECT TO CHANGE WITHOUT NOTICE.

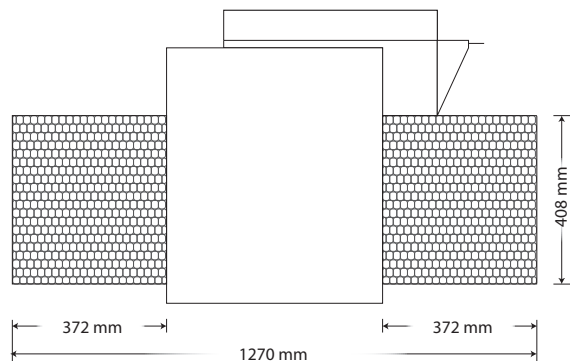
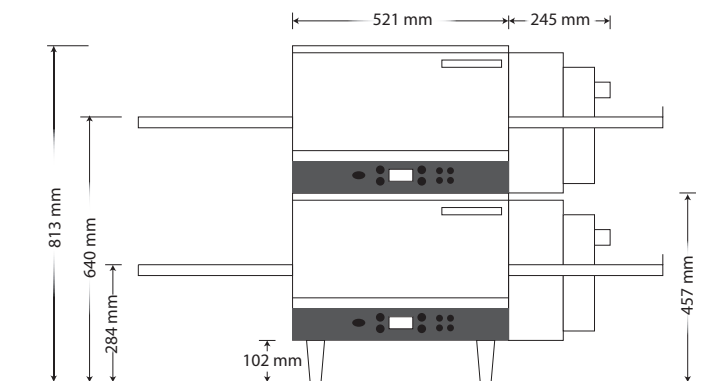
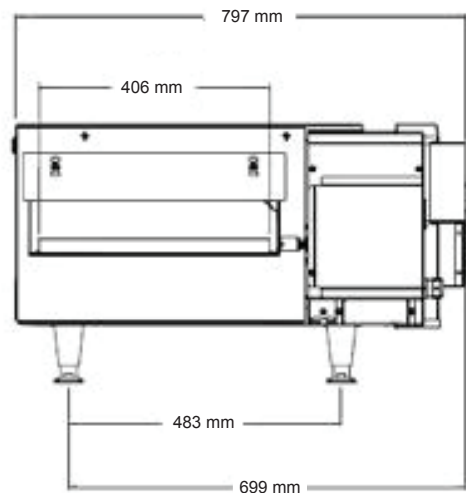

National Head Office
156 Swann Drive
Derrimut VIC 3026
Tel: +61 3 8369 4600
Fax: +61 3 8369 4699
www.comcater.com.au

Melbourne
96-100 Tope Street
South Melbourne VIC 3205
Tel: +61 3 8699 1200
Fax: +61 3 8699 1299

Sydney
20/4 Avenue of the Americas
Newington, NSW 2127
Tel: +61 2 8775 9500
Fax: +61 2 9648 4762

Brisbane
1/62 Borthwick Avenue
Murarrie QLD 4172
Tel: +61 7 3900 2700
Fax: +61 7 3399 5311

Perth
Unit 16, 7 Abrams Street
Balcatta, WA 6021
Tel: +61 8 6217 0700
Fax: +61 8 6217 0799