

Technical data sheet for

## MOFFAT SILHOUETTE 2 SLICER 12 & 15MM

Model Number SIL1215M

- Twin slice thickness 12/15 optional 13/17 (leadtime applies)
- Fitted with emergency stop button
- Standard with green start and red stop buttons
- Flat stainless steel bagging spade fitted as standard
- Gravity feed rear chute
- Durable lexan exit table



### Overall Construction

- Fitted with wheels for ease of cleaning
- Front cleaning access
- Main body of machine finished in two-pack for durability
- Rear chute fully stainless steel construction

### Operation

- Counterbalanced pusher and blade guard
- Button operation (front mounted)
- Emergency stop button front mounted

# Silhouette2

Technical data sheet for

## MOFFAT SILHOUETTE 2 SLICER 12 & 15MM

Model Number SIL1215M

### Machine Range / Output

- Sandwich slice thickness 12mm
- Toast slice thickness 15mm
- Maximum loaf length 500mm
- Maximum loaf height 140mm
- Output approx 300 loaves per frame per hour

Note: Maximum output will vary depending on the crustiness of breads being sliced and condition of slicing blades.  
300 loaves per hour is an average only.

### Specifications

- W 750mm x D 790mm x H 1630mm (with pusher disengaged)
- 400 – 415V, 3P+N+E, 50Hz, 1.0kW
- 4 pin 10A plug supplied
- Weight 200kg

### Additional Technical Information

- Power outlet to be located a minimum 1.5m off floor

### Options

- Front exit table bread bagging unit (manual load air blowing design)
- 13/17mm thickness
- SIL1215S - single loaf operation

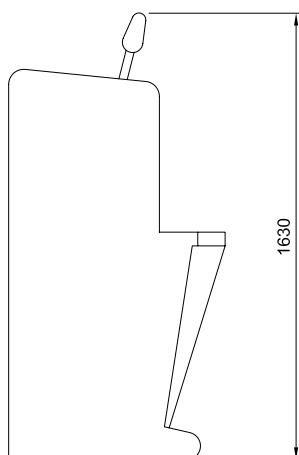
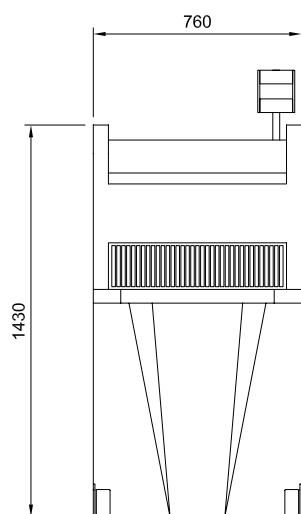
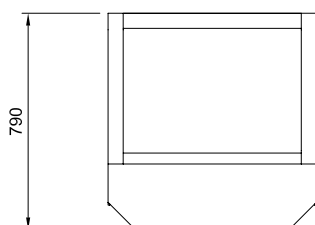

Australia  
Moffat Pty Limited

Victoria / Tasmania  
740 Springvale Rd  
Mulgrave  
Victoria 3170  
Australia  
Ph 03-9518 3888  
Fax 03-9518 3833  
Email [vsales@moffat.com.au](mailto:vsales@moffat.com.au)  
[www.moffat.com.au](http://www.moffat.com.au)

New South Wales  
Ph 02-8833 4111  
Email [nswsales@moffat.com.au](mailto:nswsales@moffat.com.au)  
[www.moffat.com.au](http://www.moffat.com.au)

South Australia  
Ph 03-9518 3888  
Email [vsales@moffat.com.au](mailto:vsales@moffat.com.au)  
[www.moffat.com.au](http://www.moffat.com.au)

Queensland  
Ph 07-3630 8600  
Email [qldsales@moffat.com.au](mailto:qldsales@moffat.com.au)  
[www.moffat.com.au](http://www.moffat.com.au)

Western Australia  
Ph 08-9202 6820  
Email [bgarcia@moffat.com.au](mailto:bgarcia@moffat.com.au)  
[www.moffat.com.au](http://www.moffat.com.au)

New Zealand  
Moffat Limited

Christchurch  
16 Osborne Street  
Christchurch 8011  
New Zealand  
Ph 03-389 1007  
Fax 03-389 1276  
Email [sales@moffat.co.nz](mailto:sales@moffat.co.nz)  
[www.moffat.co.nz](http://www.moffat.co.nz)

Auckland  
Ph 09-574 3150  
Email [sales@moffat.co.nz](mailto:sales@moffat.co.nz)  
[www.moffat.co.nz](http://www.moffat.co.nz)



In line with policy to continually develop and improve its products, Moffat Limited reserves the right to change specifications and design without notice.

Printed in China  
© Copyright Moffat Ltd

Moffat/6874/BH/03.09

