

# DEP5-670 Depositor

# Autodrop

The DEP5-670 depositor is designed to suit a wide range of products from liquid consistencies through to heavy paste type products.

Constructed from food grade stainless steel the unit is both safe to operate and also very easy to use and clean. A fully adjustable working height ensures that the operator is working in a comfortable position avoiding back and arm strain.

This unit comprises of a 60 litre guarded hopper with a height adjustable work table and castors fitted as standard. The pneumatic power lift system makes all height adjustments both quick and easy and the depositor operates by compressed air so no electrical power is required.

The multi functional design enables the operator to produce a wide variety of products using the different nozzles and spouts available. Details of the complete range of accessories are available on request.

## Specifications

Height	A	1963mm
	B	1200mm
	C	1180mm (outlet)
	D	1040mm (hopper)
Length		1000mm
Width		720mm
	1	300mm max
	2	160mm max
Dosing volume:		5 - 670ml
Weight:		65kg
Air consumption:		121 L/min at 30 deposits p/min
Energy:		Air pressure 7 bar / 101.5264 psi

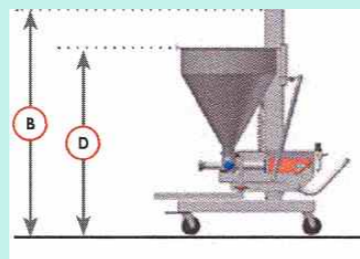
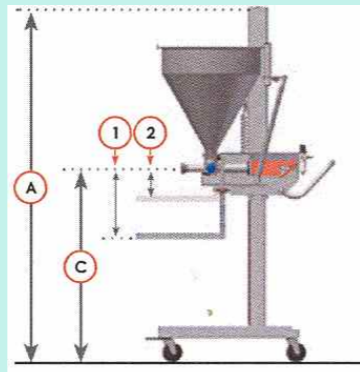

In line with policy to continually develop and improve its products, Moffat reserves the right to change specifications and design without notice

MF/0552/07.05v2



# Depositor



Note: Image shows DEP5-670 Depositor & PUMP1050 Transfer Pump



[www.moffat.com.au](http://www.moffat.com.au)

National Sales Hotline  
Toll Free 1800 023 953

Melbourne (Head Office)  
740 Springvale Road  
Mulgrave, Victoria 3170  
Telephone (613) 9518 3888  
Facsimile (613) 9518 3833  
Email: [vsales@moffat.com.au](mailto:vsales@moffat.com.au)

Sydney  
Telephone (612) 8833 4111  
Facsimile (612) 8833 4122  
Email: [nswsales@moffat.com.au](mailto:nswsales@moffat.com.au)

Adelaide  
Telephone 1800 023 953  
Facsimile (613) 9518 3833  
Email: [vsales@moffat.com.au](mailto:vsales@moffat.com.au)

Brisbane  
Telephone (617) 3630 8600  
Facsimile (617) 3630 8623  
Email: [qldsales@moffat.com.au](mailto:qldsales@moffat.com.au)

Perth  
Telephone 0419 370 150  
Facsimile (618) 9562 0385  
Email: [jberent@moffat.com.au](mailto:jberent@moffat.com.au)

Christchurch, New Zealand  
Telephone (643) 389 1007  
Facsimile (643) 389 1276  
Email: [sales@moffat.co.nz](mailto:sales@moffat.co.nz)  
Web: [www.moffat.co.nz](http://www.moffat.co.nz)

Auckland, New Zealand  
Telephone (649) 574 3150  
Facsimile (649) 574 3159  
Email: [sales@moffat.co.nz](mailto:sales@moffat.co.nz)  
Web: [www.moffat.co.nz](http://www.moffat.co.nz)

National 24 hour Service Hotline  
(Australia wide)  
Toll Free 1800 622 216

Replacement Parts  
(Australia wide)  
Toll Free 1800 337 963



# Autodrop

MF/0552/06.05v2

## NOZZLE OPTIONS

There are many different nozzles and spouts available to suit the DEP5-670 depositor. Below are examples of the most popular nozzles and their typical product applications.



Horizontal nozzle

Model	002003002 normal temp	25mm outlet
	002003008 hot temp	25mm outlet

Stainless steel horizontal nozzle with built in drip free system, operated by a stainless steel air cylinder. Maximum output 3600 pc per hour from 30ml.

Applications: Muffins, Bar cake, sponge etc



Vertical nozzle

Model	002001001 normal temp	25mm outlet
	002001008 hot temp	25mm outlet

Stainless steel vertical nozzle with built in automatic drip free system, operated by a stainless steel air cylinder. Maximum output 3600 pc per hour from 30ml.

Applications: Easy spot deposits on trays or into shells



Vertical diving nozzle

Model	002002001 normal temp	29mm outlet
	002002005 hot temp	29mm outlet

Stainless steel vertical diving nozzle with product drawback system, built in automatic drip free system and operated by a stainless steel air cylinder. Maximum output 3600 pc per hour from 20ml.

Applications: Filling custard or mousse cups



Handgun

Model	002008002 normal temp	25mm outlet
	002008006 hot temp	25mm outlet

Stainless steel handgun with built in automatic drip free system, operated by a stainless steel air cylinder. Maximum output 7200 pc per hour from 30ml.

Applications: Hand control for piping bag type applications



Decoration head

Plain or star tips available in different sizes. Details available on request.

Note: the decoration head must be used in conjunction with the vertical diving nozzle.



Double spout + injections

Model	002026001 normal & hot temp	19mm outlet	80mm apart
	002026001 normal & hot temp	19mm outlet	160mm apart

Stainless steel double spout to inject/deposit with automatic built in drip free system, operated by stainless steel air cylinder. Maximum output 4800 pc per hour from 10ml.

Applications: Jam, cream & custard fillings

Note: There are different nozzles and spouts designed to use in either 'Normal temperature' applications -7°C < +65°C or for 'Hot temperature' applications +65°C < +100°C. The same nozzle/spout cannot be used for both temperature ranges. This must be specified at time of order.

Moffat has built its reputation on a tradition of developing innovative products and supporting this with exceptional customer service.

As part of the ALI Group, one of the world's largest designers, manufacturers and suppliers of equipment to the foodservice industry, the continued success of Moffat is built around a long-term commitment to research and development and the introduction of innovative new products to the market.

The range of Moffat depositors and fillers incorporate the latest in bakery technology. They offer unique advantages over other equipment.

### Design

The AUTODROP range has been designed for the accurate dosing, filling and depositing of a vast range of products. The machines are manufactured to ensure consistency of product and to minimize production hours for the medium and larger manufacturer. All equipment can be easily disassembled for cleaning and are robust in design.

The AUTODROP range is covered by a twelve month warranty and offers great flexibility to the cake, biscuit and confectionery manufacturer.

### Features

To ensure a long working life all AUTODROP depositors and filling machines have stainless steel rollers and conveyors. Filling machines are constructed from stainless steel and offer precise dosing of various products including jams, custards, mayonnaise, sauces, creams, pipeable cake and cookies mixes.

### Applications

AUTODROP depositors and filling machines are the ideal solution for the medium sized and larger wholesale manufacturer who wishes to achieve both labour and production cost savings, along with consistency of product by means of highly accurate depositing and dosing.

