



# HOSHIZAKI ICE MACHINES

## DCM-60FE

### Product Features

- Premium Cublet Ice
- Smooth ice dispense
- No ice bridging
- Robust, reliable and sanitary
- Sanitary self-service application
- Easy operation - Push button
- Dispenses ice only, water only or ice and water
- TCP
- Adjustable portion controlled dispensing



### Range

- DCM-60FE
- DCM-110FE



## Product Specifications

- **Dimensions**  
Width: 350mm  
Depth: 480mm  
Height: 720mm
- **Weight**  
Net: 45kg  
Packed: 52kg
- **AC Supply Voltage**  
220-240V/50Hz, 10AMPs
- **Condenser**  
Air cooled
- **Refrigerant**  
R134a
- **Ambient**  
5°C - 40°C
- **Water Temp & Pressure**  
5°C - 35°C/50kpa - 800kpa
- **Ice Production per 24 hours**  
Air temp: 10°C Water temp: 10°C - approx 60kg  
Air temp: 21°C Water temp: 15°C - approx 50kg  
Air temp: 32°C Water temp: 21°C - approx 38kg
- **Ice Dispensing Rate**  
Air temp: 10°C Water temp: 10°C - approx 78 cups/30min  
Air temp: 10°C Water temp: 10°C - approx 110 cups/1hour  
Air temp: 21°C Water temp: 15°C - approx 73 cups/30min  
Air temp: 21°C Water temp: 15°C - approx 99 cups/1hour  
Air temp: 32°C Water temp: 21°C - approx 67 cups/30min  
Air temp: 32°C Water temp: 21°C - approx 87 cups/1hour
- **Maximum Storage Capacity**  
1.9kg
- **Accessories**  
Installation Kit  
Brush

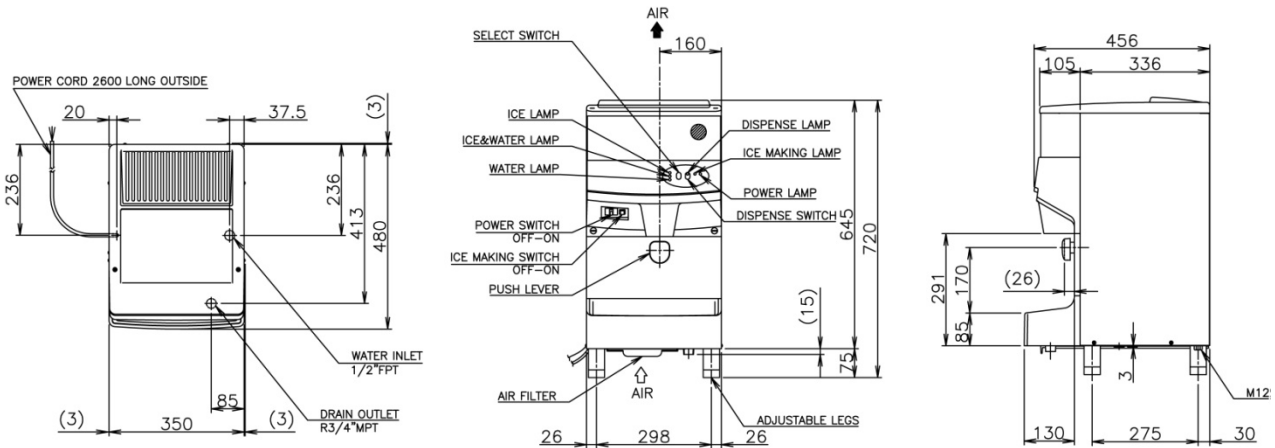



# HOSHIZAKI

## Sanitary Ice Cube Dispenser

**HYGIENIC • AUTOMATIC • CONVENIENT**

- Produce more quality ice
- Crystal clear, hard individual uniquely shaped crescent cubes that last longer in drinks
- Use less energy
- Cycle 1/2 as many times as competition
- Cubes don't clump together in storage bins
- Unique stainless steel evaporator design which is unaffected by caustic water, harsh cleaning agents and doesn't crack or peel like nickel plated evaporators
- Long life stainless steel construction
- Inbuilt, removable, easily cleaned, reusable air filters



KM-650 Ice Maker on DB200 Dispenser

Features	Benefits
<b>Totally enclosed design</b>	Ensures ice dispensing is kept to the highest possible health and safety standards
<b>Large dispense chute</b>	Large opening has been specifically designed to cater for 5 or 10 litre Willow™ jugs
<b>Huge storage</b>	Storage capacity of up to approximately 91kg of ice

*“Simply the World’s Best Ice”*



[www.hoshizaki.com.au](http://www.hoshizaki.com.au)



# Ice Dispenser Specifications

## Dispenser DB Series & Ice Machine KM (Crescent) Series

Model	HOSHIZAKI LANCER Part No.	Production per 24hr (approx)		Maximum Storage	Dimensions W x D x H	Weight (Net)	GPO Capacity
		at 21°Ca, at 15°Cw	at 32°Ca, at 21°Cw				
DB200 DISPENSER	91000063	N/A	N/A	91kg	762 x 757 x 1346	85kg	15Amp
KM515MAH-E	91000015	239kg	184kg	Select Bin	560 x 695 x 770	68kg	10Amp
KM650MAH-E	91000016	274kg	243kg	Select Bin	560 x 695 x 950	77kg	10Amp
KM-900MAH-E	91000017	392kg	321kg	Select Bin	762 x 695 x 950	98kg	15Amp



## WARRANTY

- 3 year parts and labour on entire machine
- 5 year parts and labour on KM model evaporator
- 5 year parts only on KM compressor and air cooled condenser coil
- 2 year parts and labour on DB200 dispenser

