

• **GAS BAKE & PIZZA OVEN** •

**PROUDLY AUSTRALIAN MADE**

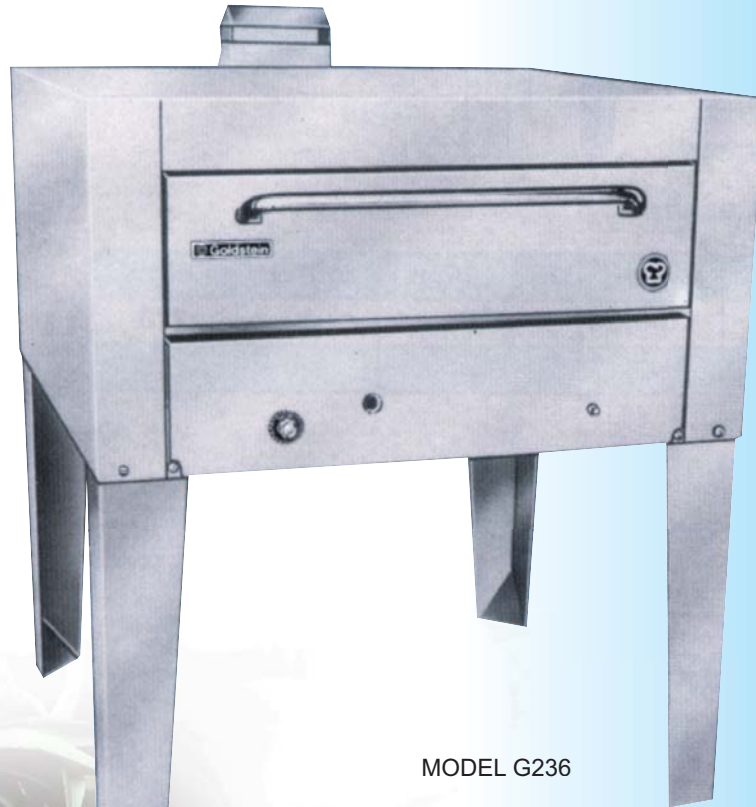

MODEL G236



**Goldstein**

Established 1911

**The Cooking Equipment Professionals**

[www.goldstein.com.au](http://www.goldstein.com.au)

# ● MODEL G236, G236/2 ● BAKE & PIZZA OVEN

## RUGGED CONSTRUCTION, HIGH PERFORMANCE

Goldsteins' G236 Pizza Oven is the ultimate in rugged, heavyweight construction coupled with large capacity and high-volume performance. The G236 is versatile, too. Ovens can be stacked for two or three deck operation, maximising use of available floor space.

Built to last and to deliver consistent, easy operation but critically controlled results, the G236 is ideal for a wide range of applications.

Economy of operations is achieved through use of sophisticated insulation materials together with even heat distribution and comprehensive controls.

## CHECK THESE SPECIAL FEATURES

- Temperature range up to 350 °C for both baking and pizzas.
- Takes two standard size baking trays.
- More pizza capacity than imported ovens
- Automatic pilot flame failure control for complete safety.
- High performance guarantees maximum production per hour.
- Stainless steel face with drop-down stainless steel door.
- Cordurice tile (fire brick) hearth (32mm thick) ensuring exceptionally even heat distribution and retention.
- Fibretex 450 rockwell urea-free insulation 100mm thick and double-faced with aluminium foil

The goldstein G236 Oven has been designed and is manufactured entirely in Australia specifically to meet the requirements of the Australian commercial kitchen. Like all other models, it is guaranteed by Goldsteins, leaders in professional cooking equipment since 1911. Sales, service and parts are available through our nationwide network of distributors in every State and Territory.

## LARGE CAPACITY FOR HIGH-VOLUME, QUALITY-CONTROLLED BAKING & PIZZAS

Goldstein's Model G236 oven takes two standard (406mmx736mm) baking trays; and can be stacked for double or treble capacity on same floor space, takes:

**9 x 250mm pizzas    5 x 355mm pizzas**  
**6 x 305mm pizzas    4 x 457mm pizzas**

Large capacity is just one of many winning features incorporated in new design of Australian requirements.

Oven comes with mild steel legs as illustrated. Stainless steel legs are available as an optional extra.

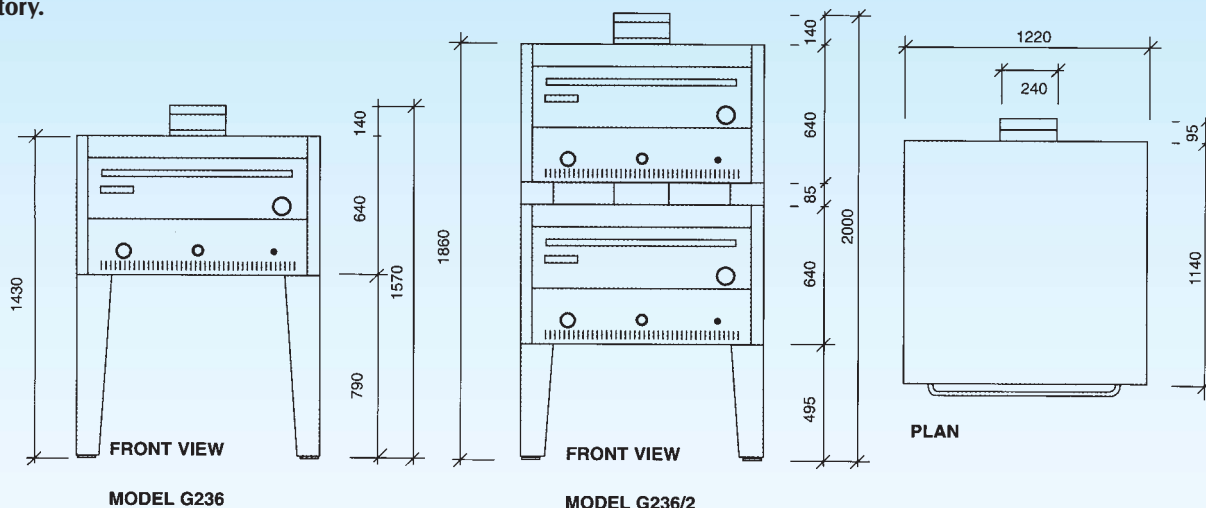

MODEL	RATING	EXT. WIDTH	DEPTH	HEIGHT	INT. WIDTH	DEPTH	HEIGHT
G236	60mj	1220	1140	640*	920	920	210
G236/2	120mj	1220	1140	1365*	920	920	210

\* Plus 140mm flue cowl.

B 35



ABN 74 000 100 845 - ABN 87 002 481 521

Group Sales: 211-213 Woodpark Rd, Smithfield NSW 2164  
Telephone (02) 9604 7333 Facsimile (02) 9604 5420  
Vic (03) 9553 1355. Qld (07) 3891 1466.  
SA (08) 8238 3423. WA (08) 9456 0559.  
Distributors: ACT (02) 6280 4088. Tas (03) 6234 8300.



Proudly Distributed by

Goldstein Eswood Continually strive to improve all of our products, therefore specifications may be amended from those printed in this brochure without notice. Publication ESW2726 05/03