

• 800 SERIES PERFORMER PLUS RANGES •
PROUDLY AUSTRALIAN MADE



Goldstein

Established 1911



The Cooking Equipment Professionals

www.goldstein.com.au

800 SERIES PERFORMER PLUS RANGES

GOLDSTEIN HEAVYWEIGHT 800 SERIES OFFERS YOU

- With the performer range you get precision control and efficient distribution of oven temperatures
- Instant top heat ready whether open burners griddle or hot top sections are selected
- Scientifically engineered construction will be found in all series of the Performer Range
- Available with solid even heat trivets interchangeable with open burner trivets
- Top cooking trivets are cast iron with built in spillage bawls designed to give greater fuel economy (up to 20%) and complete pilot protection
- Stainless steel face and sides standard
- Cast iron satellite burners are not only high powered, they also give the most even heat distribution of any range burner

SPECIFICATIONS

- All welded frame of heavy steel for rigidity and permanent alignment.
- Construction is 1.6mm steel including all linings. Oven base is 2mm steel with raised sides and back to catch spillovers. A 2mm steel baffle protects oven bottoms from direct burner flame.
- Flame failure to 20mm griddle plate standard equipment with H type cast iron burners.
- Large capacity, fully insulated and sealed ovens are designed for even distribution of heat. Ovens are ample in size for large baking and roasting pans.
- Satellite cast iron open-top burners evenly and efficiently distribute heat an 26mj each.
- Spring balanced oven door construction for trouble free operation.
- Two chrome plated oven racks standard for each oven. Non-tilting, with rear plate guard.
- Rear gas or bottom entry connections are standard.
- Optional extra flame failure open burners.

STANDARD OVEN (static)

- Heavy duty cast iron oven burners each rated 32mj per hour. Thermostats are out of the high heat zone for accurate temperatures. 100% automatic oven safety pilots are standard equipment for positive oven lighting.
- Oven interior is completely porcelain enamelled. Easy to clean prevents rusting, Gastronorm sized.
- Oven interior is easily removable for cleaning (no tools needed).

CONVECTION OVEN

- Oven interior is completely stainless steel. Easy to clean-prevents rusting.
- Unique Goldstein air distribution in the oven incorporates rear heat exchanger tubes giving more even roasting and baking.
- Heavy duty oven burners each rated at 32mj per hour. Thermostats are out of the high heat zone for accurate temperatures 100% automatic oven safety pilots are standard equipment for positive oven lighting.

SALAMANDER AND GRILL

- 12mm polished mild steel plate.
- Stainless steel radiants to cast iron burners.
- Plated wire rack to salamander.
- Large capacity grease collector.

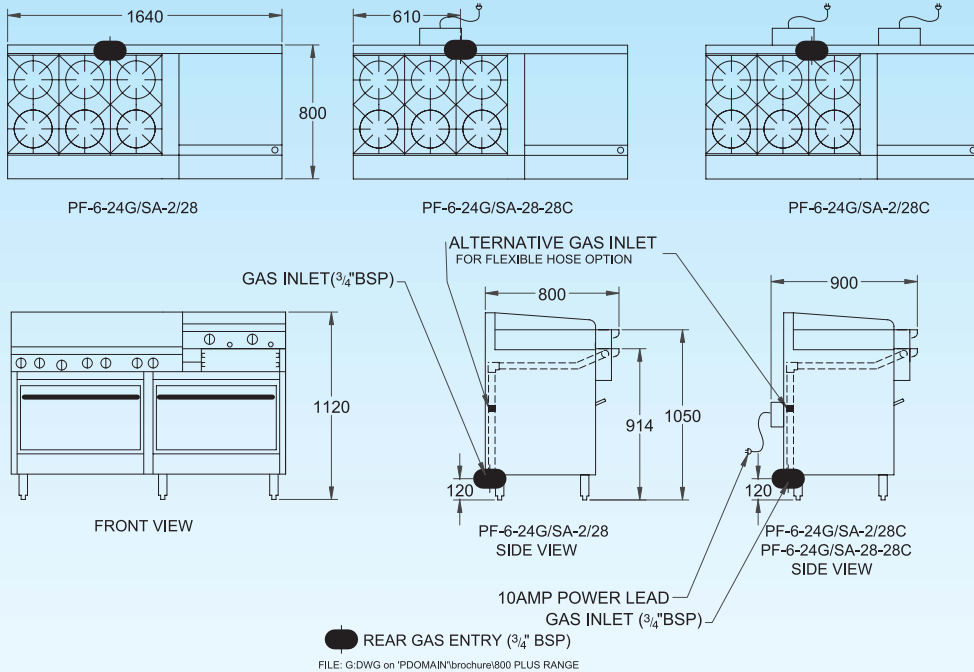

FILE: G.DWG on "PDOMAIN"brochure\800 PLUS RANGE

MODEL NUMBER	DIMENSIONS mm OVERALL			WORKING HEIGHT	OVEN			POWER INFORMATION		NET WGT KG	CUBIC M ³ PCKD		
	WIDTH	DEPTH	HEIGHT		TYPE	DIMENSIONS mm		ELEC	GAS				
						WIDTH	DEPTH		HEIGHT			MM	MJ
PF-6-24G/SA-2/28	1640	800	1120	914/1050	TWO STANDARDS (Static)	710	560	355	-	25	275	240	1.50
PF-6-24G/S-28/28C	1640	900	1120	914/1050	ONE STANDARDS (Static) ONE CONVECTION	710	560 & 470	355 & 325	1 x 10AMP	25	275	240	1.70
PF-6-24G/SA-2/28C	1640	900	1120	914/1050	TWO CONVECTIONS	710	470	325	2 x 10AMP	25	275	240	1.70

B12



ABN 74 000 100 845 - ABN 87 002 481 521

Group Sales: 211-213 Woodpark Rd, Smithfield NSW 2164
 Telephone (02) 9604 7333 Facsimile (02) 9604 5420
 Vic (03) 9553 1355. Qld (07) 3891 1466.
 SA (08) 8238 3423. WA (08) 9456 0559.
 Distributors: ACT (02) 6280 4088. Tas (03) 6234 8300.



Proudly Distributed by

Goldstein Eswood Continually strive to improve all of our products, therefore specifications may be amended from those printed in this brochure without notice Publication ESW776.0503