

• **SLIMLINE HOT FOOD CADDY** •
PROUDLY AUSTRALIAN MADE



(Illustrating perforated dish on top for holding of poached eggs)



Goldstein

Established 1911



The Cooking Equipment Professionals

www.goldstein.com.au

● SLIMLINE HOT FOOD CADDY ●

MODEL 2-HFC

An ideal unit for Nursing Homes, Coffee Shops, Private Hospitals and small restaurants.

This heated food dispenser is manufactured with all stainless steel exterior with a heated section under and the Bain Marie dishes are immersed in a heated water bath for ideal storage.

The standard dish arrangement is :-

Three (3) 1/3¹/₄ 3 size (321mm x 177mm x 150 mm deep)

Two (2) 1/2 size (321mm x 264mm x 150 mm deep)

The optional extra is a perforated dish which allows the holding of poached eggs for a breakfast application in Nursing Homes.

(All illustrated).



(Illustrating storage underneath)

SPECIFICATIONS

CONSTRUCTION

- 0.9mm 300 series stainless steel exterior
- 1800 watt element to Bain Marie.
- 600 watt element to heated storage cabinet.
- 0.9mm mild steel electrolytically plated interior.
- 1.6mm mild steel electrolytically plated base.

CASTORS

Double ball bearing zinc-plated swivel castors with poly-propylene wheel. (Two with brakes).

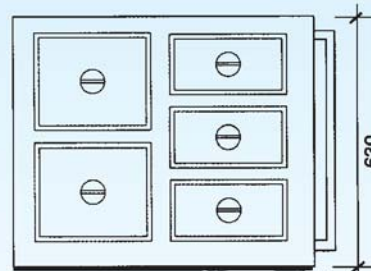
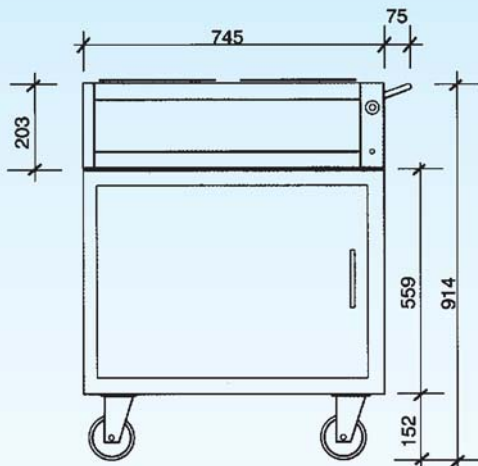

MODEL	W	D	H	OVEN SIZE			RATING
				W	D	H	
2 HFC	745	630	914	600	500	450	2.4 Kw 240V

B62



ABN 74 000 100 845 - ABN 87 002 481 521

Group Sales: 211-213 Woodpark Rd, Smithfield NSW 2164
 Telephone (02) 9604 7333 Facsimile (02) 9604 5420
 Vic (03) 9553 1355. Qld (07) 3891 1466.
 SA (08) 8238 3423. WA (08) 9456 0559.
 Distributors: ACT (02) 6280 4088. Tas (03) 6234 8300.



Proudly Distributed by

Goldstein Eswood Continually strive to improve all of our products, therefore specifications may be amended from those printed in this brochure without notice Publication ESW776.0503