

specifications

PG800HC

SKOPE Pegasus Horizontal 2/1
INTEGRAL 3 Door Chiller (JK2303)

CABINET DIMENSIONS

	External	Internal
Height:	771mm*	565mm
Width:	2435mm	1935mm
Depth:	828mm	650mm
Floor area:	2.02m ²	

* Height includes plinth and worktop (excludes castors and adjustable legs).

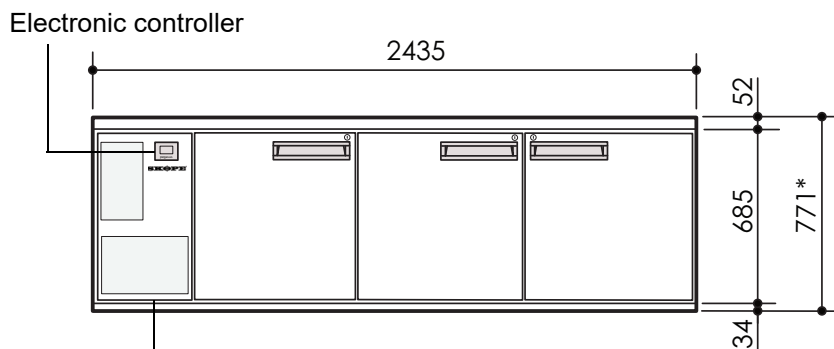
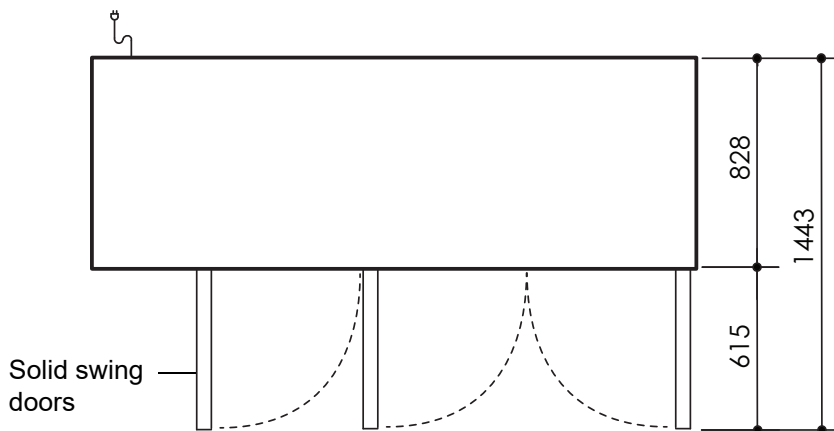

Pictured with optional 50mm stainless steel worktop

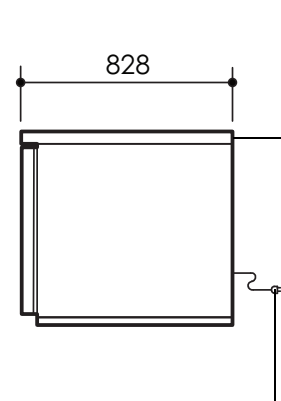

Side mounted integral refrigeration unit

Power cord with 3-Pin plug

Copyright © 2012 SKOPE Industries Limited

CABINET SPECIFICATIONS

Refrigeration system:	Electronic controlled, side mounted, integral refrigeration unit
Refrigerant:	R134a / 530g
Nominal capacity:	599 Watts @ -10°C SST
Cabinet internal volume:	750 litres
Insulation:	60mm thick, high density cyclo-isopentane polyurethane foam
Cabinet temperature range:	+1°C to +4°C up to 43°C ambient
Drainage:	No plumbing required
Electrical:	230-240 Volts a.c. 50 Hz, 3.67 Amps
Internal lighting:	n.a.
Internal door opening size:	3 door openings: 565mm high x 565mm wide
Door:	Solid stainless steel, self-closing doors (with key lock) - LH, LH, RH hinged
Worktop (optional):	Optional 50mm square edged stainless steel worktop
Shelves:	Two levels of non-tip, adjustable tray slides and/or shelves per door
Weight:	150 kg

SKOPE Industries Limited reserve the right to alter specifications without notice.

PSS0199 Rev 2.2 Aug. 2017



SKOPE INDUSTRIES LIMITED



New Zealand Freephone: 0800 947 5673, Fax: (03) 983 3896. Australian Freephone: 1800 121 535, Freefax: 1800 121 533

Email: enquiry@skope.co.nz Website: www.skope.co.nz