

SPECIFICATIONS

MPT1401

Top Mount 2-Door Cabinet Chiller

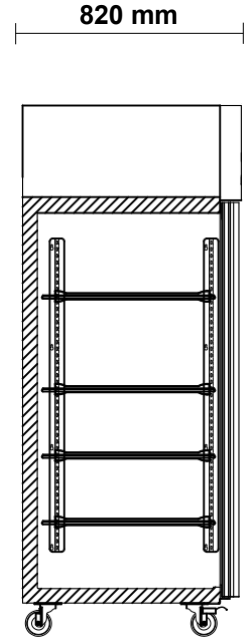
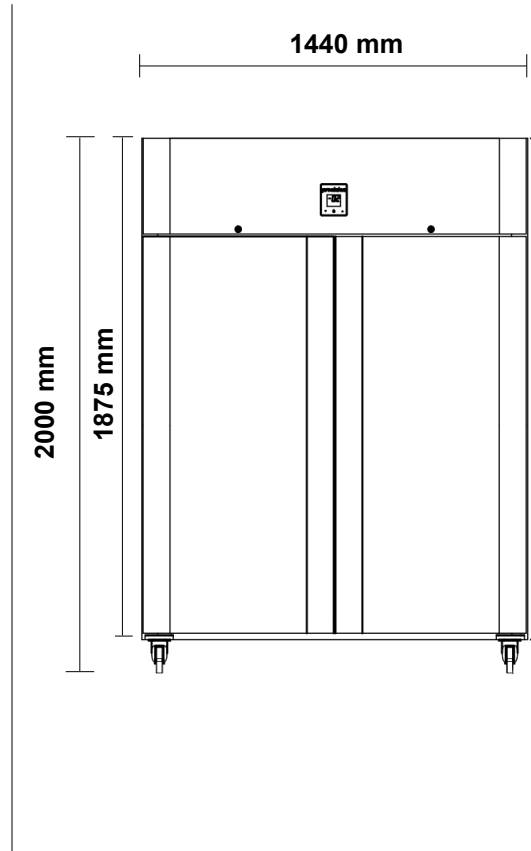

SPECIFICATIONS

Refrigeration system	Electronic controlled, self-contained, top mounted, refrigeration unit		
Refrigerant	R134a / 370g		
Nominal capacity	572 Watts @ -10°C SST		
Cabinet internal volume	1400 litres		
Insulation	60mm thick, high density, Zero ODP injected polyurethane insulation		
Cabinet temperature range	-2°C to +4°C up to 43°C ambient		
Drainage	Waste heat vaporiser located in service compartment (no plumbing required)		
Electrical	220 - 240 Volts a.c. 50 Hz, 4.6 Amps		
Internal door opening size	2 door opening: Accepts full 1/1 & 1/2GN pans		
Doors	Stainless steel, self-closing, lockable solid door		
Shelves	4 shelves & adjustable tray slides per door (530mm wide x 650mm deep)		
Weight	210 kg		
Cabinet dimensions	External	Internal	
	Width	1440mm	1320mm
	Depth	820mm	685mm
	Height	1875mm*	1405mm

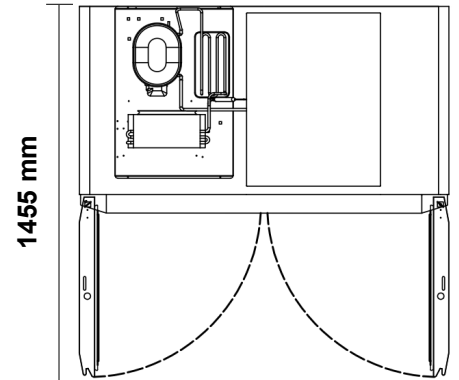

OPTIONS

- Glass doors
- Half doors
- Legs (Std on castors)
- Extra shelves
- Extra slides
- ST/ST back
- Helicoil Cable
- Hydrocarbon refrigerant
- Remote

* Height excludes castors or legs