

SPECIFICATIONS

MCU423-UDDDD

520 Series 4-Door Integral Counter Chiller

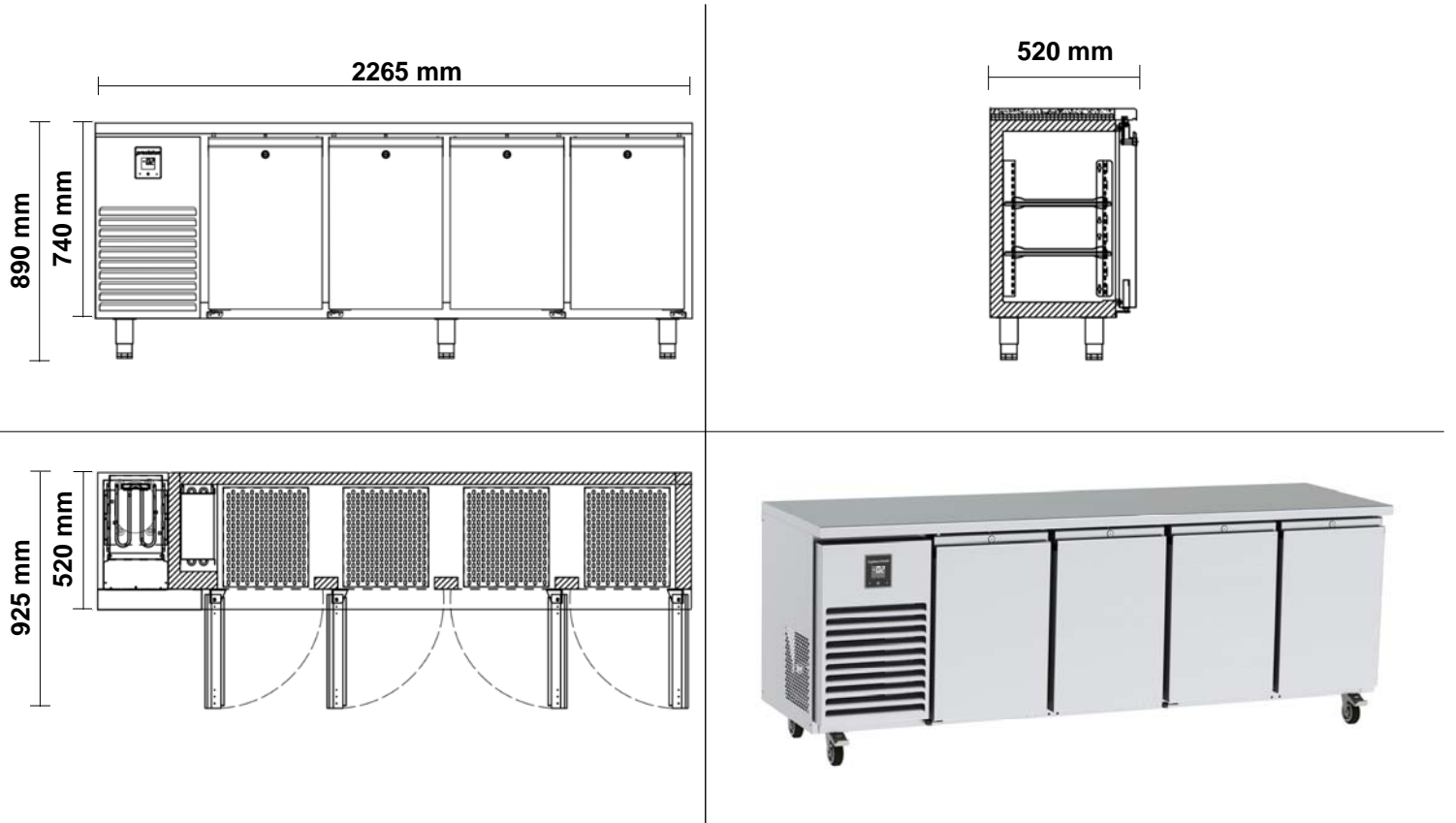

SPECIFICATIONS			
Refrigeration system	Electronic controlled, self-contained, side mounted, refrigeration unit		
Refrigerant	R134a / 160g		
Nominal capacity	412 Watts @ -10°C SST		
Cabinet internal volume	240 litres		
Insulation	60mm thick, high density Zero ODP injected polyurethane insulation		
Cabinet temperature range	-2°C to +4°C up to 43°C ambient		
Drainage	Waste heat vaporiser located in service compartment (no plumbing required)		
Electrical	220-240 Volts a.c. 50 Hz, 1.7 Amps		
kWh/24hr	4.47		
Internal door opening size	4 door opening, accepts full 2/3 or 2 x 1/3 GN pans		
Doors	Stainless steel, self-closing, lockable solid door		
Worktop	Removable stainless steel worktop		
Shelves	2 shelves & adjustable tray slides per door (Total 8)		
Weight	145kg		
Cabinet dimensions	External	Internal	
	Width	2265mm	1745mm
	Depth	520mm	400mm
	Height	700mm*	600mm

OPTIONS
• Glass Doors
• Bank of 2 Drawers
• Bank of 3 Drawers
• Remote Units
• Castors (standard on 150mm legs)
• Splashbacks
• Extended Worktops
• No Worktop
• Different Heights
• Raised Pan Grid
• Countertop Well
• Over-shelf / Gantry
• Water-cooled
• Extra Shelves
• Extra Slides
• ST/ST Back
• Heli-coil Cable
• Hydrocarbon Refrigerant
• HFO Refrigerant

* Height excludes castors, legs or SS worktop