

SPECIFICATIONS

LPT1401

Top Mount 2-Door Cabinet Freezer

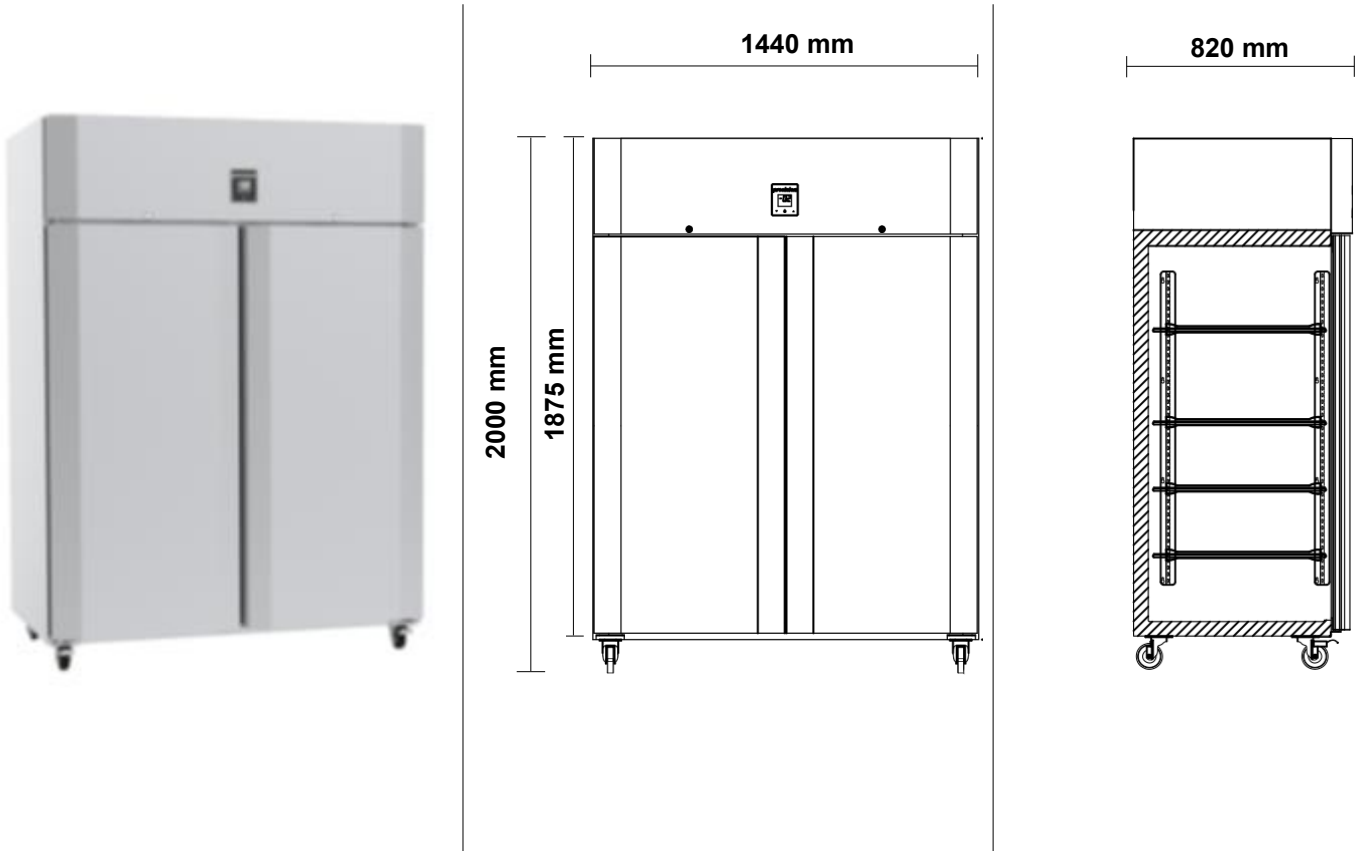

SPECIFICATIONS			
Refrigeration system	Electronic controlled, self-contained, top mounted, refrigeration unit		
Refrigerant	R404a / 400g		
Nominal capacity	900 Watts @ -30°C SST		
Cabinet internal volume	1400 litres		
Insulation	60mm thick, high density, Zero ODP injected polyurethane insulation		
Cabinet temperature range	-18°C to -22°C up to 43°C ambient		
Drainage	Waste heat vaporiser located in service compartment (no plumbing required)		
Electrical	220 - 240 Volts a.c. 50 Hz, 5.5 Amps		
Internal door opening size	2 door opening: Accepts full 1/1 & 1/2GN pans		
Doors	Stainless steel, self-closing, lockable solid door		
Shelves	4 shelves & adjustable tray slides per door (530mm wide x 650mm deep)		
Weight	230 kg		
Cabinet dimensions	External	Internal	
	Width	1440mm	1320mm
	Depth	820mm	685mm
	Height	1875mm*	1405mm

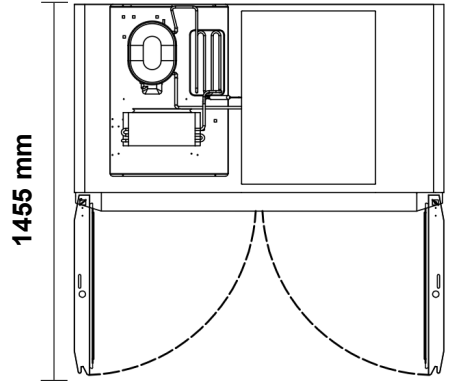

OPTIONS
• Glass doors
• Half doors
• Legs (Std on castors)
• Extra shelves
• Extra slides
• ST/ST back
• Helicoil Cable
• Hydrocarbon refrigerant
• Remote

* Height excludes castors or legs